



PCA38-12 BATTERY

AGM DEEP CYCLE

SPECIFICATION

Nominal Voltage	12V	
Nominal Capacity(10HR)	38.0AH	
Dimension	Length	197±2mm (7.76 inches)
	Width	165±2mm (6.50 inches)
	Container Height	170±2mm (6.69 inches)
	Total Height (with Terminal)	170±2mm (6.69 inches)
Approx Weight	Approx 11.65Kg	
Terminal	T6	
Container Material	ABS	
Rated Capacity	40.8AH/2.04A	(20hr, 1.80V/cell, 25 °C/77 °F)
	38.0AH/3.80A	(10hr, 1.80V/cell, 25 °C/77 °F)
	33.4AH/6.67A	(5hr, 1.75V/cell, 25 °C/77 °F)
	30.3AH/10.1A	(3hr, 1.75V/cell, 25 °C/77 °F)
	24.5AH/24.5A	(1hr, 1.60V/cell, 25 °C/77 °F)
Max. Discharge Current	456A (5s)	
Internal Resistance	Approx 9.0mOhm	
Operating Temperature	Discharge	-15 ~ 50°C (5 ~ 122°F)
	Charge	0 ~ 40°C (32 ~ 104°F)
	Storage	-15 ~ 40°C (5 ~ 104°F)
Nominal Operating Temperature	25 ± 3°C (77 ± 5°F)	
Cycle Use	Initial Charging Current less than 11.4A. Voltage 14.4V~15.0V at 25°C (77°F) Temp. Coefficient -30mV/°C	
	Standby Use	
Capacity affected by Temperature	40°C (104°F)	103%
	25°C (77°F)	100%
	0°C (32°F)	86%
Self Discharge	Prime PCA series batteries may be stored for up to 6 months at 25°C (77°F) and then a freshening charge is required. For higher temperatures the time interval will be shorter.	

Applications

- Electric tools
- Vehicle in place of walking
- Lawn mowers
- Golf trolleys and golf cart
- Portable apparatus, lights and instruments;
- Electric toys
- Illumination light
- Fire alarms
- Portable power
- Wheelchairs
- Medical equipments.

DIMENSIONS

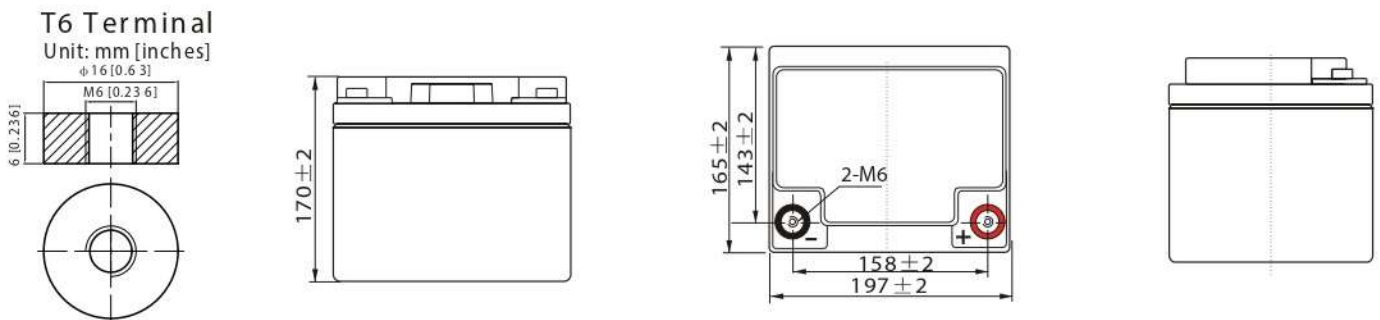

Discharge Characteristics

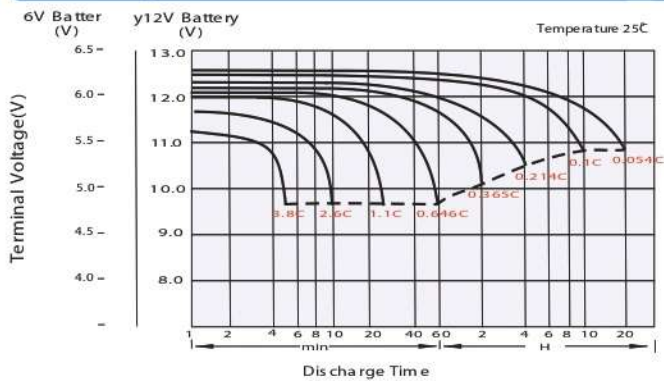

Charging Characteristics (cycle use)

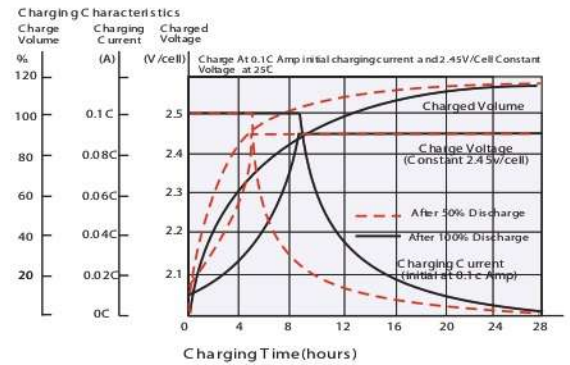

Temperature Effects in Relation to Battery Capacity

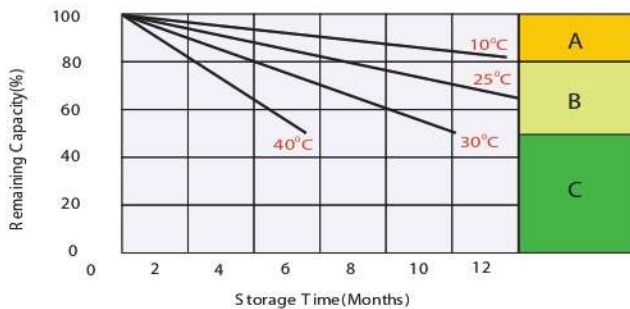
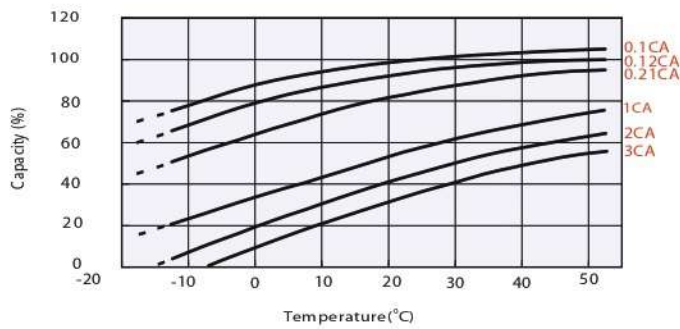

Cycle Life in Relation to Depth of Discharge

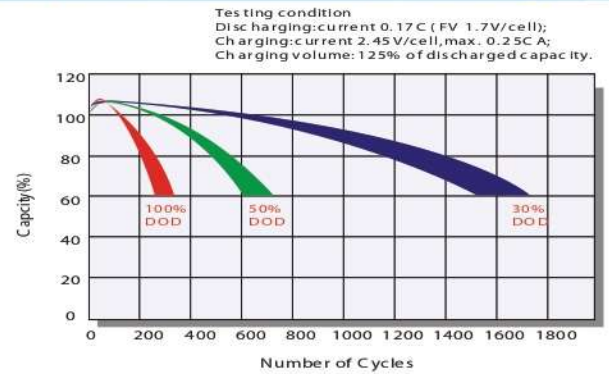

Self Discharge Characteristics

- A** No supplementary charge required
(Carry out supplementary charge before use if 100% capacity is required.)
- B** Supplementary charge required before use. Optional charging way as be low:
 1. Charged for above 3 days at limited current 0.25CA and constant voltage 2.25V/cell.
 2. Charged for above 20 hours at limited current 0.25CA and constant voltage 2.45V/cell.
 3. Charged for 8~10 hours at limited current 0.05CA.
- C** Supplementary charge may often fail to recover the capacity.
The battery should never be left standing till this is reached.

Constant Current Discharge (Amperes) at 25°C (77°F)

F.V/Time	10min	15min	20min	30min	45min	1h	2h	3h	4h	5h	6h	8h	10h	20h
1.85V/cell	55.6	46.8	40.9	29.4	23.4	19.0	11.8	9.19	7.44	6.05	5.28	4.31	3.59	2.02
1.80V/cell	71.1	56.6	48.4	34.7	27.2	21.3	12.9	9.89	7.95	6.49	5.66	4.57	3.80	2.04
1.75V/cell	78.1	61.8	52.0	36.1	28.2	22.2	13.3	10.1	8.12	6.67	5.81	4.65	3.84	2.06
1.70V/cell	85.1	66.0	54.7	37.5	29.3	22.9	13.9	10.4	8.34	6.83	5.94	4.71	3.88	2.09
1.65V/cell	91.9	70.1	58.1	39.6	30.1	23.7	14.3	10.8	8.63	7.02	6.06	4.79	3.96	2.12
1.60V/cell	99.8	75.0	61.9	41.8	31.4	24.5	14.7	11.1	8.90	7.25	6.20	4.83	4.00	2.13

Constant Power Discharge (Watts/cell) at 25°C (77°F)

F.V/Time	10min	15min	20min	30min	45min	1h	2h	3h	4h	5h	6h	8h	10h	20h
1.85V/cell	103.8	88.3	78.0	56.6	45.2	36.8	23.0	18.0	14.6	11.9	10.42	8.52	7.11	4.04
1.80V/cell	130.9	105.1	90.8	65.9	52.2	41.0	24.9	19.2	15.5	12.7	11.14	9.02	7.52	4.07
1.75V/cell	142.0	113.6	96.8	68.1	53.9	42.7	25.8	19.5	15.8	13.0	11.43	9.17	7.59	4.10
1.70V/cell	152.6	120.4	101.2	70.6	55.9	44.0	26.7	20.0	16.2	13.3	11.65	9.29	7.66	4.18
1.65V/cell	163.6	127.2	107.0	74.2	57.1	45.3	27.4	20.8	16.7	13.7	11.89	9.43	7.81	4.22
1.60V/cell	174.6	134.4	112.8	77.5	58.9	46.5	28.1	21.4	17.2	14.1	12.12	9.51	7.89	4.24

Specifications subject to change without notice.