

PCA100-12 BATTERY

AGM DEEP CYCLE



SPECIFICATION

Nominal Voltage	12V	
Nominal Capacity(10HR)	100.0AH	
Dimension	Length	330±3mm (12.99 inches)
	Width	173±2mm (6.81 inches)
	Container Height	212±3mm (8.35 inches)
	Total Height (with Terminal)	220±3mm (8.66 inches)
Approx Weight	Approx 28.00 Kg	
Terminal	T11	
Container Material	ABS	
Rated Capacity	107.2AH/5.36A	(20hr, 1.80V/cell, 25°C/77°F)
	100.0AH/10.0A	(10hr, 1.80V/cell, 25°C/77°F)
	87.7 AH/17.5A	(5hr, 1.75V/cell, 25°C/77°F)
	79.5AH/26.5A	(3hr, 1.75V/cell, 25°C/77°F)
	64.6AH/64.6A	(1hr, 1.60V/cell, 25°C/77°F)
Max. Discharge Current	1200A (5s)	
Internal Resistance	Approx 4.9mΩ	
Operating Temp. Range	Discharge	-15~50°C (5~122°F)
	Charge	0~40°C (32~104°F)
	Storage	-15~40°C (5~104°F)
Nominal Operating Temp. Range	25±3°C (77±5°F)	
Cycle Use	Initial Charging Current less than 30.0A. Voltage 14.4V~15.0V at 25°C(77°F)Temp. Coefficient -30mV/°C	
	No limit on Initial Charging Current Voltage	
Standby Use	13.5V~13.8V at 25°C(77°F)Temp. Coefficient -20mV/°C	
Capacity affected by Temperature	40°C (104°F)	103%
	25°C (77°F)	100%
	0°C (32°F)	86%
Self Discharge	Prime PCA series batteries may be stored for up to 6 months at 25°C(77°F) and then a freshening charge is required. For higher temperatures the time interval will be shorter.	

Applications

- Electric tools
- Vehicle in place of walking
- Lawn mowers
- Golf trolleys and golf cart
- Portable apparatus, lights and instruments;
- Electric toys
- Illumination light
- Fire alarms
- Portable power
- Wheelchairs
- Medical equipments.

DIMENSIONS

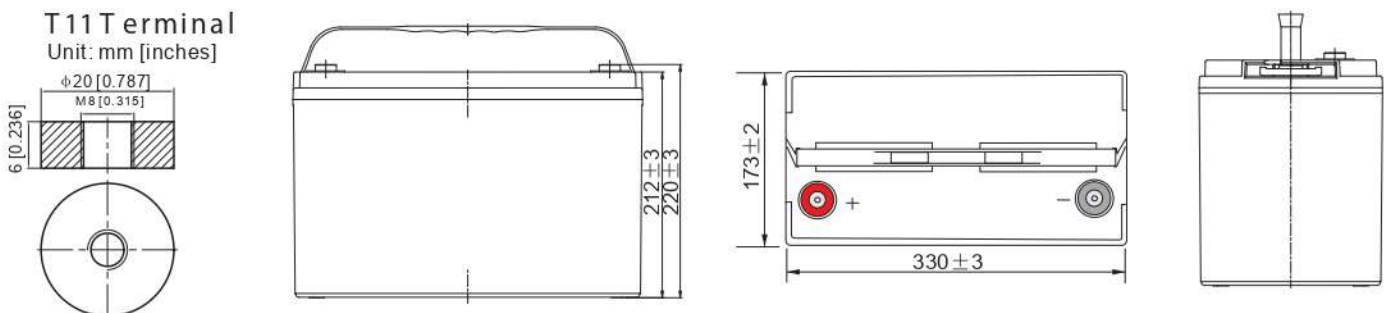

Discharge Characteristics

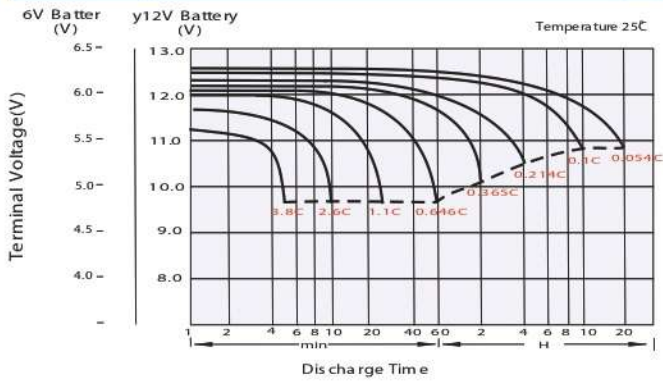

Charging Characteristics (cycle use)

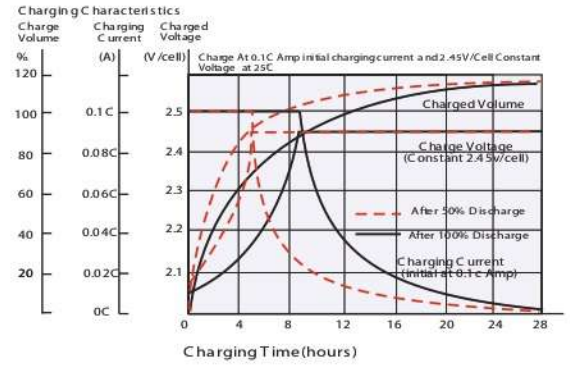

Temperature Effects in Relation to Battery Capacity

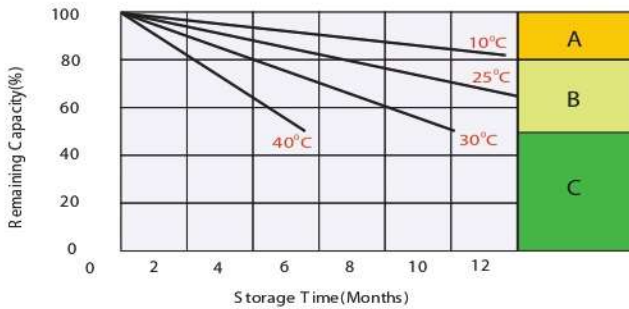
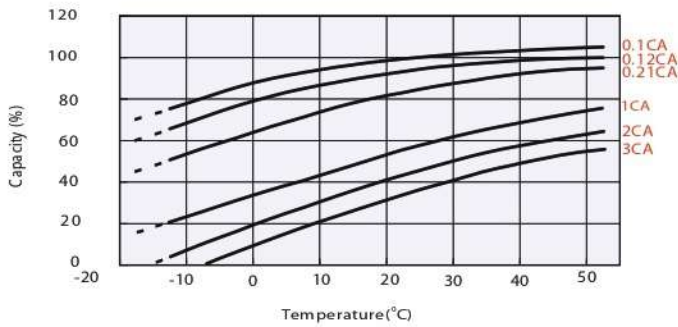

Cycle Life in Relation to Depth of Discharge

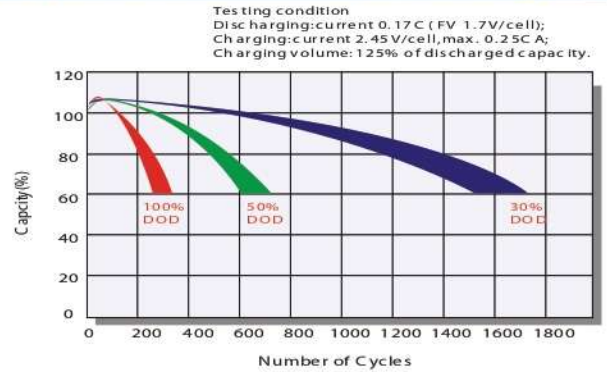

Self Discharge Characteristics

- A** No supplementary charge required
(Carry out supplementary charge before use if 100% capacity is required.)
- B** Supplementary charge required before use. Optional charging way as be low:
 1. Charged for above 3 days at limited current 0.25C A and constant voltage 2.25V / cell.
 2. Charged for above 20 hours at limited current 0.25CA and constant voltage 2.45V / cell.
 3. Charged for 8~10 hours at limited current 0.05C A.
- C** Supplementary charge may often fail to recover the capacity.
The battery should never be left standing till this is reached.

Constant Current Discharge (Amperes) at 25°C (77°F)

F.V/Time	10min	15min	20min	30min	45min	1h	2h	3h	4h	5h	6h	8h	10h	20h
1.85V/cell	146.4	123.2	107.7	77.5	61.5	49.9	31.0	24.2	19.6	15.9	13.9	11.3	9.4	5.31
1.80V/cell	187.1	148.9	127.3	91.4	71.6	55.9	33.9	26.0	20.9	17.1	14.9	12.0	10.0	5.36
1.75V/cell	205.6	162.6	136.9	94.9	74.3	58.5	35.1	26.5	21.4	17.5	15.3	12.2	10.1	5.41
1.70V/cell	224.1	173.6	143.9	98.8	77.2	60.4	36.5	27.2	22.0	18.0	15.6	12.4	10.2	5.51
1.65V/cell	241.8	184.6	152.8	104.2	79.2	62.4	37.5	28.4	22.7	18.5	16.0	12.6	10.4	5.58
1.60V/cell	262.5	197.4	162.8	110.0	82.5	64.6	38.8	29.3	23.4	19.1	16.3	12.7	10.5	5.61

Constant Power Discharge (Watts/cell) at 25°C (77°F)

F.V/Time	10min	15min	20min	30min	45min	1h	2h	3h	4h	5h	6h	8h	10h	20h
1.85V/cell	273.2	232.3	205.2	148.8	119.0	96.9	60.4	47.2	38.4	31.3	27.4	22.4	18.7	10.6
1.80V/cell	344.4	276.5	238.8	173.5	137.3	107.9	65.6	50.6	40.8	33.5	29.3	23.7	19.8	10.7
1.75V/cell	373.8	299.1	254.8	179.3	141.8	112.5	67.8	51.4	41.6	34.3	30.1	24.1	20.0	10.8
1.70V/cell	401.7	316.9	266.3	185.8	147.0	115.7	70.3	52.7	42.6	35.1	30.7	24.5	20.2	11.0
1.65V/cell	430.4	334.8	281.5	195.2	150.2	119.2	72.1	54.8	44.0	36.0	31.3	24.8	20.6	11.1
1.60V/cell	459.4	353.8	296.8	204.0	155.1	122.5	74.1	56.2	45.1	37.0	31.9	25.0	20.8	11.2

Specifications subject to change without notice.