



Descrizione: SPL è la serie di lampioni fotovoltaici da arredo urbano Western CO con batteria a piombo o litio (LiFePO₄). Presentano un nuovo design compatto, migliori prestazioni in termini di durata della batteria, maggiore efficienza e una maggiore garanzia di accensione lampada anche nei periodi di cattivo tempo e scarsa insolazione. Il lampione è composto dal modulo fotovoltaico, dalla batteria a tecnologia piombo o litio (LiFePO₄), dal regolatore di carica, dalla lampada a led alta efficienza con ottica asimmetrica ottimizzata per illuminazione di strade o parcheggi e dalla struttura meccanica in acciaio verniciato a polvere epossidica per il montaggio del modulo e della batteria in testa al palo. Western CO fornisce a richiesta anche il palo altezza 4.5metri fuori terra.

<i>Modelli</i>	<i>Potenza Lampada flusso pieno</i>	<i>Modulo PV</i>	<i>Batteria</i>	<i>Pag.</i>
SPL-12W	12.2W	100W	GEL 58Ah	2
SPL-18W	18.4W	100W	GEL 58Ah	3
SPL-12W-Li-30Ah	12.2W	100W	LiFePO4 30Ah	4
SPL-18W-Li-30Ah	18.4W	100W	LiFePO4 30Ah	5
SPL-18W-Li-60Ah	18.4W	100W	LiFePO4 60Ah	6

cod. 019124	Modello: SPL-12W
<p>Regolatore di carica SPC07-IP2</p> 	<p>-Circuito di carica della batteria tipo PWM ottimizzato per impiego su lampione fotovoltaico -Accensione automatica notturna su uscita lampada con timer a numero di ore limitato (12 ore) e programmabile (la lampada si accende automaticamente la notte per un numero limitato di ore per notte). -Gestione automatica della riduzione di flusso programmabile al 70% 50% e 25%. -Settaggio gestione lampada attraverso dip-switch interni al circuito. -Ricarica ottimizzata per batterie al litio (LiFePo4 con tensione 14.4V e batterie al piombo GEL), protezione della carica in caso di temperatura < 0°C e > 45°C. (settaggio tramite dip-switch del tipo di batteria). -Protezione batteria da scarica profonde. -Protezione alla penetrazione di liquido e solidi IP56 (EN 60529). -Garanzia del produttore 5 anni. -Conforme a: Direttiva 2004/108/CE – EMC (EN 61000-6-1 e EN 61000-6-3) Direttiva 2006/95/CE – Bassa Tensione (EN 62109-1)</p>
<p>Lampada Sun Light XS 12 Dark Grey</p> 	<p>Lampada a led ad alta efficienza. -Corpo in alluminio estruso e anodizzato nero, grado protezione alla penetrazione di solidi e liquidi IP65(EN 60529). -Potenza lampada 12W. -Flusso apparecchio 1830lm. -Efficienza sorgente 150lm/W efficienza apparecchio 147lm/W. -Temperatura di colore 4000K, CRI minimo 70. -Optica stradale ad alta efficienza. Rilievi fotometrici dell'apparecchio formato elettronico LDT. -Conforme a DECRETO 27 settembre 2017 (Ministero dell'Ambiente e della tutela del Territorio e del mare) decreto CAM, Criteri Ambientali Minimi per l'acquisizione di sorgenti luminose per illuminazione pubblica. -Garanzia produttore 5 anni.</p>
<p>Batteria</p> 	<p>N° 1 Batteria con caratteristiche: -Tipologia ermetica al Piombo GEL senza manutenzione -Capacità 58Ah a 12.0V nominali. -Peso 19.0 Kg -intervallo operativo di scarica da -10°C a 55°C. -Vita ciclica >1500 cicli a 50% DOD (Deep Of Discharge).</p>
<p>Modulo fotovoltaico Modello: UFX100PM</p> 	<p>-Celle poly cristallino ad alta efficienza, certificato secondo le normative IEC 61215 e IEC 61730. -Garanzia sulla potenza resa > 90% entro 12 anni e maggiore dell'85% entro 25 anni. -Carico meccanico fino a 5400Pa (N/m²). -Scatola di giunzione protetta alla penetrazione liquidi o solidi IP65 (EN 60529). -Potenza 100W (dimensioni 1.015m x 0.668m) -Garanzia produttore 5 anni.</p>
<p>Accessori meccanici per montaggio modulo PV, batteria in testa al palo e lampada</p> 	<p>-Struttura meccanica e accessori in acciaio verniciato a polvere epossidica colore grigio colore grigio RAL 7043 -Costruito secondo EN 1090 (Esecuzione di strutture in acciaio ed alluminio) e corredato della relativa DoP (Dichiarazione di Prestazione). -Calcolo strutturale secondo Eurocodice 0, 1, 3 e DM 17/01/2018 Ministero delle Infrastrutture e dei Trasporti (Norme Tecniche delle Costruzioni).</p>

cod. 019125	Modello: SPL-18W
Regolatore di carica SPC07-IP2 	-Circuito di carica della batteria tipo PWM ottimizzato per impiego su lampione fotovoltaico -Accensione automatica notturna su uscita lampada con timer a numero di ore limitato (12 ore) e programmabile (la lampada si accende automaticamente la notte per un numero limitato di ore per notte). -Gestione automatica della riduzione di flusso programmabile al 70% 50% e 25% . -Settaggio gestione lampada attraverso dip-switch interni al circuito. -Ricarica ottimizzata per batterie al litio (LiFePo4 con tensione 14.4V e batterie al piombo GEL), protezione della carica in caso di temperatura < 0°C e > 45°C. (settaggio tramite dip-switch del tipo di batteria). -Protezione batteria da scarica profonde. -Protezione alla penetrazione di liquido e solidi IP56 (EN 60529). -Garanzia del produttore 5 anni . -Conforme a: Direttiva 2004/108/CE – EMC (EN 61000-6-1 e EN 61000-6-3) Direttiva 2006/95/CE – Bassa Tensione (EN 62109-1)
Lampada Sun Light XS 18 Dark Grey 	Lampada a led ad alta efficienza. -Corpo in alluminio estruso e anodizzato nero, grado protezione alla penetrazione di solidi e liquidi IP65(EN 60529). -Potenza lampada 18W . -Flusso apparecchio 2695lm. -Efficienza sorgente 150lm/W efficienza apparecchio 143lm/W. -Temperatura di colore 4000K, CRI minimo 70. -Optica stradale ad alta efficienza. Rilievi fotometrici dell'apparecchio formato elettronico LDT. -Conforme a DECRETO 27 settembre 2017 (Ministero dell'Ambiente e della tutela del Territorio e del mare) decreto CAM, Criteri Ambientali Minimi per l'acquisizione di sorgenti luminose per illuminazione pubblica. -Garanzia produttore 5 anni .
Batteria 	N° 1 Batteria con caratteristiche: -Tipologia ermetica al Piombo GEL senza manutenzione -Capacità 58Ah a 12.0V nominali. -Peso 19.0 Kg -intervallo operativo di scarica da -10°C a 55°C. -Vita ciclica >1500 cicli a 50% DOD (Deep Of Discharge).
Modulo fotovoltaico Modello: UFX100PM 	-Celle poly cristallino ad alta efficienza, certificato secondo le normative IEC 61215 e IEC 61730 . -Garanzia sulla potenza resa > 90% entro 12 anni e maggiore dell'85% entro 25 anni. -Carico meccanico fino a 5400Pa (N/m ²). -Scatola di giunzione protetta alla penetrazione liquidi o solidi IP65 (EN 60529). -Potenza 100W (dimensioni 1.015m x 0.668m) -Garanzia produttore 5 anni .
Accessori meccanici per montaggio modulo PV, batteria in testa al palo e lampada 	-Struttura meccanica e accessori in acciaio verniciato a polvere epossidica colore grigio colore grigio RAL 7043 -Costruito secondo EN 1090 (Esecuzione di strutture in acciaio ed alluminio) e corredato della relativa DoP (Dichiarazione di Prestazione). -Calcolo strutturale secondo Eurocodice 0, 1, 3 e DM 17/01/2018 Ministero delle Infrastrutture e dei Trasporti (Norme Tecniche delle Costruzioni).

cod. 019126	Modello: SPL-12W-Li-30Ah
<p>Regolatore di carica SPC07-IP2</p> 	<ul style="list-style-type: none"> -Circuito di carica della batteria tipo PWM ottimizzato per impiego su lampione fotovoltaico -Accensione automatica notturna su uscita lampada con timer a numero di ore limitato (12 ore) e programmabile (la lampada si accende automaticamente la notte per un numero limitato di ore per notte). -Gestione automatica della riduzione di flusso programmabile al 70% 50% e 25%. -Settaggio gestione lampada attraverso dip-switch interni al circuito. -Ricarica ottimizzata per batterie al litio (LiFePO4 con tensione 14.4V e batterie al piombo GEL), protezione della carica in caso di temperatura < 0°C e > 45°C. (settaggio tramite dip-switch del tipo di batteria). -Protezione batteria da scarica profonde. -Protezione alla penetrazione di liquido e solidi IP56 (EN 60529). -Garanzia del produttore 5 anni. -Conforme a: <ul style="list-style-type: none"> Direttiva 2004/108/CE – EMC (EN 61000-6-1 e EN 61000-6-3) Direttiva 2006/95/CE – Bassa Tensione (EN 62109-1)
<p>Lampada Sun Light XS 12 Dark Grey</p> 	<p>Lampada a led ad alta efficienza.</p> <ul style="list-style-type: none"> -Corpo in alluminio estruso e anodizzato nero, grado protezione alla penetrazione di solidi e liquidi IP65(EN 60529). -Potenza lampada 12W. -Flusso apparecchio 1830lm. -Efficienza sorgente 150lm/W efficienza apparecchio 147lm/W. -Temperatura di colore 4000K, CRI minimo 70. -Optica stradale ad alta efficienza. Rilievi fotometrici dell'apparecchio formato elettronico LDT. -Conforme a DECRETO 27 settembre 2017 (Ministero dell'Ambiente e della tutela del Territorio e del mare) decreto CAM, Criteri Ambientali Minimi per l'acquisizione di sorgenti luminose per illuminazione pubblica. -Garanzia produttore 5 anni.
<p>Batteria</p> 	<p>Batteria a litio</p> <ul style="list-style-type: none"> -Tipologia LiFePO4 ad elevata sicurezza. -Capacità 30Ah a 12.8V nominali. -Bilanciamento interno delle celle e protezione interna da sovraccarica in tensione, sovraccarico in corrente sia in carica che in scarica, sovra-temperatura. -Intervallo di temperatura operativo da -10°C a 55°C; intervallo temperatura in carica da +0°C a 45°C e intervallo operativo di scarica da -10°C a 55°C. -Vita ciclica >2500 cicli a 80% DOD (Deep Of Discharge). -Conforme a UN 38.3 Lithium ion battery safety testing.
<p>Modulo fotovoltaico Modello: UFX100PM</p> 	<ul style="list-style-type: none"> -Celle poly cristallino ad alta efficienza, certificato secondo le normative IEC 61215 e IEC 61730. -Garanzia sulla potenza resa > 90% entro 12 anni e maggiore dell'85% entro 25 anni. -Carico meccanico fino a 5400Pa (N/m²). -Scatola di giunzione protetta alla penetrazione liquidi o solidi IP65 (EN 60529). -Potenza 100W (dimensioni 1.015m x 0.668m) -Garanzia produttore 5 anni.
<p>Accessori meccanici per montaggio modulo PV, batteria in testa al palo e lampada</p> 	<ul style="list-style-type: none"> -Struttura meccanica e accessori in acciaio verniciato a polvere epossidica colore grigio colore grigio RAL 7043 -Costruito secondo EN 1090 (Esecuzione di strutture in acciaio ed alluminio) e corredato della relativa DoP (Dichiarazione di Prestazione). -Calcolo strutturale secondo Eurocodice 0, 1, 3 e DM 17/01/2018 Ministero delle Infrastrutture e dei Trasporti (Norme Tecniche delle Costruzioni).

cod. 019127	Modello: SPL-18W-Li-30Ah
<p>Regolatore di carica SPC07-IP2</p> 	<p>-Circuito di carica della batteria tipo PWM ottimizzato per impiego su lampione fotovoltaico -Accensione automatica notturna su uscita lampada con timer a numero di ore limitato (12 ore) e programmabile (la lampada si accende automaticamente la notte per un numero limitato di ore per notte). -Gestione automatica della riduzione di flusso programmabile al 70% 50% e 25%. -Settaggio gestione lampada attraverso dip-switch interni al circuito. -Ricarica ottimizzata per batterie al litio (LiFePo4 con tensione 14.4V e batterie al piombo GEL), protezione della carica in caso di temperatura < 0°C e > 45°C. (settaggio tramite dip-switch del tipo di batteria). -Protezione batteria da scarica profonde. -Protezione alla penetrazione di liquido e solidi IP56 (EN 60529). -Garanzia del produttore 5 anni. -Conforme a: Direttiva 2004/108/CE – EMC (EN 61000-6-1 e EN 61000-6-3) Direttiva 2006/95/CE – Bassa Tensione (EN 62109-1)</p>
<p>Lampada Sun Light XS 18 Dark Grey</p> 	<p>Lampada a led ad alta efficienza. -Corpo in alluminio estruso e anodizzato nero, grado protezione alla penetrazione di solidi e liquidi IP65(EN 60529). -Potenza lampada 18W. -Flusso apparecchio 2695lm. -Efficienza sorgente 150lm/W efficienza apparecchio 143lm/W. -Temperatura di colore 4000K, CRI minimo 70. -Optica stradale ad alta efficienza. Rilievi fotometrici dell'apparecchio formato elettronico LDT. -Conforme a DECRETO 27 settembre 2017 (Ministero dell'Ambiente e della tutela del Territorio e del mare) decreto CAM, Criteri Ambientali Minimi per l'acquisizione di sorgenti luminose per illuminazione pubblica. -Garanzia produttore 5 anni.</p>
<p>Batteria</p> 	<p>Batteria a litio -Tipologia LiFePO4 ad elevata sicurezza. -Capacità 30Ah a 12.8V nominali. -Bilanciamento interno delle celle e protezione interna da sovraccarica in tensione, sovraccarico in corrente sia in carica che in scarica, sovra-temperatura. -Intervallo di temperatura operativo da -10°C a 55°C; intervallo temperatura in carica da +0°C a 45°C e intervallo operativo di scarica da -10°C a 55°C. -Vita ciclica >2500 cicli a 80% DOD (Deep Of Discharge). -Conforme a UN 38.3 Lithium ion battery safety testing.</p>
<p>Modulo fotovoltaico Modello: UFX100PM</p> 	<p>-Celle poly cristallino ad alta efficienza, certificato secondo le normative IEC 61215 e IEC 61730. -Garanzia sulla potenza resa > 90% entro 12 anni e maggiore dell'85% entro 25 anni. -Carico meccanico fino a 5400Pa (N/m²). -Scatola di giunzione protetta alla penetrazione liquidi o solidi IP65 (EN 60529). -Potenza 100W (dimensioni 1.015m x 0.668m) -Garanzia produttore 5 anni.</p>
<p>Accessori meccanici per montaggio modulo PV, batteria in testa al palo e lampada</p> 	<p>-Struttura meccanica e accessori in acciaio verniciato a polvere epossidica colore grigio RAL 7043 -Costruito secondo EN 1090 (Esecuzione di strutture in acciaio ed alluminio) e corredato della relativa DoP (Dichiarazione di Prestazione). -Calcolo strutturale secondo Eurocodice 0, 1, 3 e DM 17/01/2018 Ministero delle Infrastrutture e dei Trasporti (Norme Tecniche delle Costruzioni).</p>

cod. 019128	Modello: SPL-18W-Li-60Ah
<p>Regolatore di carica SPC07-IP2</p> 	<p>-Circuito di carica della batteria tipo PWM ottimizzato per impiego su lampione fotovoltaico -Accensione automatica notturna su uscita lampada con timer a numero di ore limitato (12 ore) e programmabile (la lampada si accende automaticamente la notte per un numero limitato di ore per notte). -Gestione automatica della riduzione di flusso programmabile al 70% 50% e 25%. -Settaggio gestione lampada attraverso dip-switch interni al circuito. -Ricarica ottimizzata per batterie al litio (LiFePo4 con tensione 14.4V e batterie al piombo GEL), protezione della carica in caso di temperatura < 0°C e > 45°C. (settaggio tramite dip-switch del tipo di batteria). -Protezione batteria da scarica profonde. -Protezione alla penetrazione di liquido e solidi IP56 (EN 60529). -Garanzia del produttore 5 anni. -Conforme a: Direttiva 2004/108/CE – EMC (EN 61000-6-1 e EN 61000-6-3) Direttiva 2006/95/CE – Bassa Tensione (EN 62109-1)</p>
<p>Lampada Sun Light XS 18 Dark Grey</p> 	<p>Lampada a led ad alta efficienza. -Corpo in alluminio estruso e anodizzato nero, grado protezione alla penetrazione di solidi e liquidi IP65(EN 60529). -Potenza lampada 18W. -Flusso apparecchio 2695lm. -Efficienza sorgente 150lm/W efficienza apparecchio 143lm/W. -Temperatura di colore 4000K, CRI minimo 70. -Ottica stradale ad alta efficienza. Rilievi fotometrici dell'apparecchio formato elettronico LDT. -Conforme a DECRETO 27 settembre 2017 (Ministero dell'Ambiente e della tutela del Territorio e del mare) decreto CAM, Criteri Ambientali Minimi per l'acquisizione di sorgenti luminose per illuminazione pubblica. -Garanzia produttore 5 anni.</p>
<p>Batteria</p> 	<p>Batteria a litio -Tipologia LiFePO4 ad elevata sicurezza. -Capacità 60Ah a 12.8V nominali. -Bilanciamento interno delle celle e protezione interna da sovraccarica in tensione, sovraccarico in corrente sia in carica che in scarica, sovra-temperatura. -Intervallo di temperatura operativo da -10°C a 55°C; intervallo temperatura in carica da +0°C a 45°C e intervallo operativo di scarica da -10°C a 55°C. -Vita ciclica >2500 cicli a 80% DOD (Deep Of Discharge). -Conforme a UN 38.3 Lithium ion battery safety testing.</p>
<p>Modulo fotovoltaico Modello: UFX100PM</p> 	<p>-Celle poly cristallino ad alta efficienza, certificato secondo le normative IEC 61215 e IEC 61730. -Garanzia sulla potenza resa > 90% entro 12 anni e maggiore dell'85% entro 25 anni. -Carico meccanico fino a 5400Pa (N/m²). -Scatola di giunzione protetta alla penetrazione liquidi o solidi IP65 (EN 60529). -Potenza 100W (dimensioni 1.015m x 0.668m) -Garanzia produttore 5 anni.</p>
<p>Accessori meccanici per montaggio modulo PV, batteria in testa al palo e lampada</p> 	<p>-Struttura meccanica e accessori in acciaio verniciato a polvere epossidica colore grigio RAL 7043 -Costruito secondo EN 1090 (Esecuzione di strutture in acciaio ed alluminio) e corredato della relativa DoP (Dichiarazione di Prestazione). -Calcolo strutturale secondo Eurocodice 0, 1, 3 e DM 17/01/2018 Ministero delle Infrastrutture e dei Trasporti (Norme Tecniche delle Costruzioni).</p>

Dimensioni

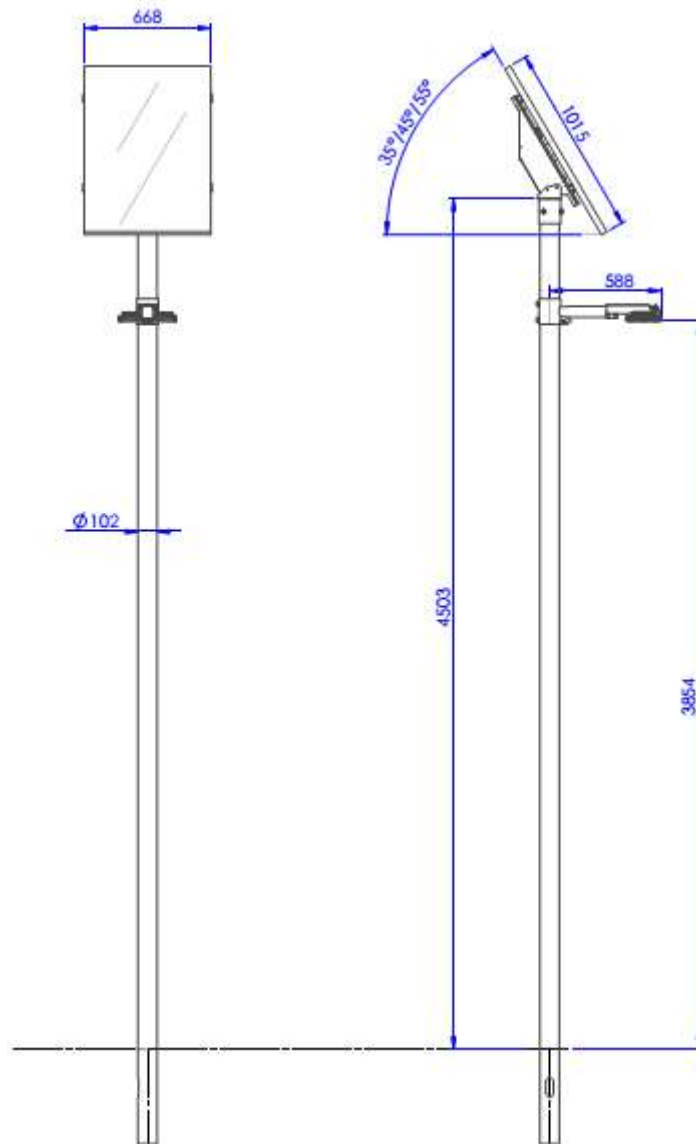



Description: SPL is Western CO series of photovoltaic street lamps with lead or lithium battery (LiFePO₄). They have a new compact design, better performance in terms of battery life, greater efficiency and a greater guarantee of lamp ignition even in periods of bad weather and low insolation. The street lamp is made up of the photovoltaic module, the lead or lithium battery (LiFePO₄), the charge controller, the high efficiency LED lamp with asymmetrical optics optimized for street or parking lighting and the mechanical structure in epoxy powder coated steel. for mounting the module and the battery on top of the pole. Western CO also supplies the pole height 4.5 meters above ground on request.

Models	Lamp Power full flux	PV Module	Battery	Pag.
SPL-12W	12.2W	100W	GEL 58Ah	2
SPL-18W	18.4W	100W	GEL 58Ah	3
SPL-12W-Li-30Ah	12.2W	100W	LiFePO4 30Ah	4
SPL-18W-Li-30Ah	18.4W	100W	LiFePO4 30Ah	5
SPL-18W-Li-60Ah	18.4W	100W	LiFePO4 60Ah	6

cod. 019124	Model: SPL-12W
<p>Charge controller SPC07-IP2</p> 	<ul style="list-style-type: none"> - PWM type battery charging circuit optimized for use on photovoltaic street lamps -Automatic night lighting on lamp output with a limited number of hours (12 hours) and programmable timer (the lamp turns on automatically at night for a limited number of hours per night). -Automatic management of the flow reduction programmable at 70% 50% and 25%. - Lamp management setting through dip-switches inside the circuit. - Optimized charging for lithium batteries (LiFePo4 with 14.4V voltage and lead GEL batteries), charge protection in case of temperatures <0 ° C and > 45 ° C. (setting by dip-switch of the type of battery). - Battery protection from deep discharge. -Protection against penetration of liquids and solids IP56 (EN 60529). - 5 year manufacturer's warranty. -Complies with: <ul style="list-style-type: none"> Directive 2004/108 / EC - EMC (EN 61000-6-1 and EN 61000-6-3) Directive 2006/95 / EC - Low Voltage (EN 62109-1)
<p>Lamp Sun Light XS 12 Dark Grey</p> 	<ul style="list-style-type: none"> -High efficiency led lamp. -Body in extruded and black anodized aluminum, degree of protection against penetration of solids and liquids IP65 (EN 60529). - Lamp power 12W. - Fixture flux 1830lm. - Source efficiency 150lm / W luminaire efficiency 147lm / W. - Color temperature 4000K, minimum CRI 70. -High efficiency street optics. Photometric measurements of the LDT electronic format device. -Complies with DECREE 27 September 2017 (Ministry of the Environment and Land and Sea Protection) CAM decree, Minimum Environmental Criteria for the acquisition of light sources for public lighting. - 5 year manufacturer warranty.
<p>Battery</p> 	<ul style="list-style-type: none"> N ° 1 Battery with features: -Type hermetic Lead GEL without maintenance -Capacity 58Ah at 12.0V nominal. -Weight 19.0 Kg -operating range of discharge from -10 ° C to 55 ° C. - Cyclic life > 1500 cycles at 50% DOD (Deep Of Discharge).
<p>PV Module Model: UFX100PM</p> 	<ul style="list-style-type: none"> -High efficiency crystalline poly cells, certified according to IEC 61215 and IEC 61730 standards. -Guarantee on power output > 90% within 12 years and greater than 85% within 25 years. -Mechanical load up to 5400Pa (N / m2). -Junction box protected against liquid or solid penetration IP65 (EN 60529). -Power 100W (dimensions 1.015m x 0.668m) - 5 year manufacturer warranty.
<p>Mechanical accessories for mounting the PV module, pole-top battery and lamp</p> 	<ul style="list-style-type: none"> -Mechanical structure and accessories in epoxy powder coated steel, RAL 7043 gray color. -Built according to EN 1090 (Execution of steel and aluminum structures) and accompanied by the relative DoP (Declaration of Performance). -Structural calculation according to Eurocode 0, 1, 3 and Ministerial Decree 17/01/2018 Ministry of Infrastructure and Transport (Technical Construction Standards).

cod. 019125	Model: SPL-18W
<p>Charge controller SPC07-IP2</p> 	<ul style="list-style-type: none"> - PWM type battery charging circuit optimized for use on photovoltaic street lamps -Automatic night lighting on lamp output with a limited number of hours (12 hours) and programmable timer (the lamp turns on automatically at night for a limited number of hours per night). -Automatic management of the flow reduction programmable at 70% 50% and 25%. - Lamp management setting through dip-switches inside the circuit. - Optimized charging for lithium batteries (LiFePO4 with 14.4V voltage and lead GEL batteries), charge protection in case of temperatures <0 ° C and > 45 ° C. (setting by dip-switch of the type of battery). - Battery protection from deep discharge. -Protection against penetration of liquids and solids IP56 (EN 60529). - 5 year manufacturer's warranty. -Complies with: <ul style="list-style-type: none"> Directive 2004/108 / EC - EMC (EN 61000-6-1 and EN 61000-6-3) Directive 2006/95 / EC - Low Voltage (EN 62109-1)
<p>Lamp Sun Light XS 18 Dark Grey</p> 	<p>High efficiency led lamp.</p> <ul style="list-style-type: none"> -Body in extruded and black anodized aluminum, degree of protection against penetration of solids and liquids IP65 (EN 60529). - Lamp power 18W. - Fixture flux 2695lm. - Source efficiency 150lm / W luminaire efficiency 143lm / W. - Color temperature 4000K, minimum CRI 70. -High efficiency street optics. Photometric measurements of the LDT electronic format device. -Complies with DECREE 27 September 2017 (Ministry of the Environment and Land and Sea Protection) CAM decree, Minimum Environmental Criteria for the acquisition of light sources for public lighting. - 5 year manufacturer warranty.
<p>Battery</p> 	<p>N ° 1 Battery with features:</p> <ul style="list-style-type: none"> -Type hermetic Lead GEL without maintenance -Capacity 58Ah at 12.0V nominal. -Weight 19.0 Kg -operating range of discharge from -10 ° C to 55 ° C. - Cyclic life > 1500 cycles at 50% DOD (Deep Of Discharge).
<p>PV Module Model: UFX100PM</p> 	<ul style="list-style-type: none"> -High efficiency crystalline poly cells, certified according to IEC 61215 and IEC 61730 standards. -Guarantee on power output > 90% within 12 years and greater than 85% within 25 years. -Mechanical load up to 5400Pa (N / m2). -Junction box protected against liquid or solid penetration IP65 (EN 60529). -Power 100W (dimensions 1.015m x 0.668m) - 5 year manufacturer warranty.
<p>Mechanical accessories for mounting the PV module, pole-top battery and lamp</p> 	<ul style="list-style-type: none"> -Mechanical structure and accessories in epoxy powder coated steel, RAL 7043 gray color. -Built according to EN 1090 (Execution of steel and aluminum structures) and accompanied by the relative DoP (Declaration of Performance). -Structural calculation according to Eurocode 0, 1, 3 and Ministerial Decree 17/01/2018 Ministry of Infrastructure and Transport (Technical Construction Standards).

cod. 019126	Model: SPL-12W-Li-30Ah
<p>Charge controller SPC07-IP2</p> 	<ul style="list-style-type: none"> - PWM type battery charging circuit optimized for use on photovoltaic street lamps -Automatic night lighting on lamp output with a limited number of hours (12 hours) and programmable timer (the lamp turns on automatically at night for a limited number of hours per night). -Automatic management of the flow reduction programmable at 70% 50% and 25%. - Lamp management setting through dip-switches inside the circuit. - Optimized charging for lithium batteries (LiFePO4 with 14.4V voltage and lead GEL batteries), charge protection in case of temperatures <0 ° C and > 45 ° C. (setting by dip-switch of the type of battery). - Battery protection from deep discharge. -Protection against penetration of liquids and solids IP56 (EN 60529). - 5 year manufacturer's warranty. -Complies with: <ul style="list-style-type: none"> Directive 2004/108 / EC - EMC (EN 61000-6-1 and EN 61000-6-3) Directive 2006/95 / EC - Low Voltage (EN 62109-1)
<p>Lamp Sun Light XS 12 Dark Grey</p> 	<p>High efficiency led lamp.</p> <ul style="list-style-type: none"> -Body in extruded and black anodized aluminum, degree of protection against penetration of solids and liquids IP65 (EN 60529). - Lamp power 12W. - Fixture flux 1830lm. - Source efficiency 150lm / W luminaire efficiency 147lm / W. - Color temperature 4000K, minimum CRI 70. -High efficiency street optics. Photometric measurements of the LDT electronic format device. -Complies with DECREE 27 September 2017 (Ministry of the Environment and Land and Sea Protection) CAM decree, Minimum Environmental Criteria for the acquisition of light sources for public lighting. - 5 year manufacturer warranty.
<p>Battery</p> 	<p>Lithium battery</p> <ul style="list-style-type: none"> - High security LiFePO4 type. -Capacity 30Ah at 12.8V nominal. -Internal cell balancing and internal protection against voltage overcharge, current overload both in charging and discharging, over-temperature. -Operating temperature range from -10 ° C to 55 ° C; charging temperature range from + 0 ° C to 45 ° C and discharge operating range from -10 ° C to 55 ° C. -Cyclic life > 2500 cycles at 80% DOD (Deep Of Discharge). -Complies with UN 38.3 Lithium ion battery safety testing.
<p>PV Module Model: UFX100PM</p> 	<ul style="list-style-type: none"> -High efficiency crystalline poly cells, certified according to IEC 61215 and IEC 61730 standards. -Guarantee on power output > 90% within 12 years and greater than 85% within 25 years. -Mechanical load up to 5400Pa (N / m2). -Junction box protected against liquid or solid penetration IP65 (EN 60529). -Power 100W (dimensions 1.015m x 0.668m) - 5 year manufacturer warranty.
<p>Mechanical accessories for mounting the PV module, pole-top battery and lamp</p> 	<ul style="list-style-type: none"> -Mechanical structure and accessories in epoxy powder coated steel, RAL 7043 gray color. -Built according to EN 1090 (Execution of steel and aluminum structures) and accompanied by the relative DoP (Declaration of Performance). -Structural calculation according to Eurocode 0, 1, 3 and Ministerial Decree 17/01/2018 Ministry of Infrastructure and Transport (Technical Construction Standards).

cod. 019127	Model: SPL-18W-Li-30Ah
<p>Charge controller SPC07-IP2</p> 	<ul style="list-style-type: none"> - PWM type battery charging circuit optimized for use on photovoltaic street lamps -Automatic night lighting on lamp output with a limited number of hours (12 hours) and programmable timer (the lamp turns on automatically at night for a limited number of hours per night). -Automatic management of the flow reduction programmable at 70% 50% and 25%. - Lamp management setting through dip-switches inside the circuit. - Optimized charging for lithium batteries (LiFePo4 with 14.4V voltage and lead GEL batteries), charge protection in case of temperatures <0 ° C and > 45 ° C. (setting by dip-switch of the type of battery). - Battery protection from deep discharge. -Protection against penetration of liquids and solids IP56 (EN 60529). - 5 year manufacturer's warranty. -Complies with: <ul style="list-style-type: none"> Directive 2004/108 / EC - EMC (EN 61000-6-1 and EN 61000-6-3) Directive 2006/95 / EC - Low Voltage (EN 62109-1)
<p>Lamp Sun Light XS 18 Dark Grey</p> 	<ul style="list-style-type: none"> -High efficiency led lamp. -Body in extruded and black anodized aluminum, degree of protection against penetration of solids and liquids IP65 (EN 60529). - Lamp power 18W. - Fixture flux 2695lm. - Source efficiency 150lm / W luminaire efficiency 143lm / W. - Color temperature 4000K, minimum CRI 70. -High efficiency street optics. Photometric measurements of the LDT electronic format device. -Complies with DECREE 27 September 2017 (Ministry of the Environment and Land and Sea Protection) CAM decree, Minimum Environmental Criteria for the acquisition of light sources for public lighting. - 5 year manufacturer warranty.
<p>Battery</p> 	<ul style="list-style-type: none"> -Lithium battery - High security LiFePO4 type. -Capacity 30Ah at 12.8V nominal. -Internal cell balancing and internal protection against voltage overcharge, current overload both in charging and discharging, over-temperature. -Operating temperature range from -10 ° C to 55 ° C; charging temperature range from + 0 ° C to 45 ° C and discharge operating range from -10 ° C to 55 ° C. -Cyclic life > 2500 cycles at 80% DOD (Deep Of Discharge). -Complies with UN 38.3 Lithium ion battery safety testing.
<p>PV Module Model: UFX100PM</p> 	<ul style="list-style-type: none"> -High efficiency crystalline poly cells, certified according to IEC 61215 and IEC 61730 standards. -Guarantee on power output > 90% within 12 years and greater than 85% within 25 years. -Mechanical load up to 5400Pa (N / m2). -Junction box protected against liquid or solid penetration IP65 (EN 60529). -Power 100W (dimensions 1.015m x 0.668m) - 5 year manufacturer warranty.
<p>Mechanical accessories for mounting the PV module, pole-top battery and lamp</p> 	<ul style="list-style-type: none"> -Mechanical structure and accessories in epoxy powder coated steel, RAL 7043 gray color. -Built according to EN 1090 (Execution of steel and aluminum structures) and accompanied by the relative DoP (Declaration of Performance). -Structural calculation according to Eurocode 0, 1, 3 and Ministerial Decree 17/01/2018 Ministry of Infrastructure and Transport (Technical Construction Standards).

cod. 019128	Model: SPL-18W-Li-60Ah
<p>Charge controller SPC07-IP2</p> 	<ul style="list-style-type: none"> - PWM type battery charging circuit optimized for use on photovoltaic street lamps -Automatic night lighting on lamp output with a limited number of hours (12 hours) and programmable timer (the lamp turns on automatically at night for a limited number of hours per night). -Automatic management of the flow reduction programmable at 70% 50% and 25%. - Lamp management setting through dip-switches inside the circuit. - Optimized charging for lithium batteries (LiFePo4 with 14.4V voltage and lead GEL batteries), charge protection in case of temperatures <0 ° C and> 45 ° C. (setting by dip-switch of the type of battery). - Battery protection from deep discharge. -Protection against penetration of liquids and solids IP56 (EN 60529). - 5 year manufacturer's warranty. -Complies with: <ul style="list-style-type: none"> Directive 2004/108 / EC - EMC (EN 61000-6-1 and EN 61000-6-3) Directive 2006/95 / EC - Low Voltage (EN 62109-1)
<p>Lamp Sun Light XS 18 Dark Grey</p> 	<ul style="list-style-type: none"> -High efficiency led lamp. -Body in extruded and black anodized aluminum, degree of protection against penetration of solids and liquids IP65 (EN 60529). - Lamp power 18W. - Fixture flux 2695lm. - Source efficiency 150lm / W luminaire efficiency 143lm / W. - Color temperature 4000K, minimum CRI 70. -High efficiency street optics. Photometric measurements of the LDT electronic format device. -Complies with DECREE 27 September 2017 (Ministry of the Environment and Land and Sea Protection) CAM decree, Minimum Environmental Criteria for the acquisition of light sources for public lighting. - 5 year manufacturer warranty.
<p>Battery</p> 	<ul style="list-style-type: none"> -Lithium battery - High security LiFePO4 type. -Capacity 60Ah at 12.8V nominal. -Internal cell balancing and internal protection against voltage overcharge, current overload both in charging and discharging, over-temperature. -Operating temperature range from -10 ° C to 55 ° C; charging temperature range from + 0 ° C to 45 ° C and discharge operating range from -10 ° C to 55 ° C. -Cyclic life> 2500 cycles at 80% DOD (Deep Of Discharge). -Complies with UN 38.3 Lithium ion battery safety testing.
<p>PV Module Model: UFX100PM</p> 	<ul style="list-style-type: none"> -High efficiency crystalline poly cells, certified according to IEC 61215 and IEC 61730 standards. -Guarantee on power output> 90% within 12 years and greater than 85% within 25 years. -Mechanical load up to 5400Pa (N / m2). -Junction box protected against liquid or solid penetration IP65 (EN 60529). -Power 100W (dimensions 1.015m x 0.668m) - 5 year manufacturer warranty.
<p>Mechanical accessories for mounting the PV module, pole-top battery and lamp</p> 	<ul style="list-style-type: none"> -Mechanical structure and accessories in epoxy powder coated steel, RAL 7043 gray color. -Built according to EN 1090 (Execution of steel and aluminum structures) and accompanied by the relative DoP (Declaration of Performance). -Structural calculation according to Eurocode 0, 1, 3 and Ministerial Decree 17/01/2018 Ministry of Infrastructure and Transport (Technical Construction Standards).

Dimensions

